

ProHeat™ 35

Rolling Induction System

Induction Heating System 

Quick Specs

Applications

Process piping
Refinery
Petrochemical
Power piping
Pressure vessels

Maximum Preheat Temperature

600°F (315°C)

Input Power

460–575 V, 3-phase, 60 Hz
400–460 V, 3-phase, 50/60 Hz

Input Amperes at Rated Output

400 V: 60 amps
460 V: 50 amps
575 V: 40 amps

Rated Output

One rolling inductor: 20 kW at 100% duty cycle
Two rolling inductors: 35 kW at 100% duty cycle

Power Source Dimensions

H: 27.5 in. (699 mm)
W: 21.75 in. (552 mm)
D: 36.75 in. (933 mm)

Power Source Weight

Net: 227 lb. (103 kg) Ship: 265 lb. (120 kg)

Powering a heating revolution – for preheat of moving parts up to 600 degrees Fahrenheit (315°C).

The ProHeat 35 rolling induction system is a simple and cost-effective heating solution which delivers fast and consistent heat for pipe fabrication shops that weld pipe spools for the refinery, petrochemical, power and HVAC industries.

Optimal consistency and quality

- The rolling induction system eliminates the inconsistencies and quality issues associated with open-flame-torch heating methods
- Temperature measurement allows operators to set and achieve targeted preheat temperatures easily with limited button pushing
- The travel detect system prevents hot spots by controlling output based on travel speeds and turning output off if the part is not moving



ProHeat 35 power source shown with heavy-duty induction cooler (951686) and optional running gear (195436).



Rolling inductor is specially designed for heating moving parts. Shown with optional mounting arm (301119), travel detect system (301183) and infrared temperature sensor (301149).

Improved safety

- Eliminates open flames, reducing burn as well as fumes and explosive gas hazards
- Direct heat transfer results in cooler shop environment that reduces operator fatigue and improves work conditions

Maximum productivity

- Quick time to temperature increases production efficiencies while reducing consumable costs and labor expenses
- Heating while rolling the pipe assembly allows for continuous fabrication
- Compact and portable to configure around various pipe sizes throughout the fabrication shop



Miller Electric Mfg. LLC
An ITW Welding Company
1635 West Spencer Street
P.O. Box 1079
Appleton, WI 54912-1079 USA

Equipment Sales US and Canada
Phone: 866-931-9730
FAX: 800-637-2315
International Phone: 920-735-4554
International FAX: 920-735-4125

MillerWelds.com



ProHeat™ 35 Rolling Induction System

ProHeat 35 Power Source

907689 460–575 V

907690 400–460 V, CE

The ProHeat 35 induction power source is equipped with a built-in temperature controller allowing for manual or temperature-based programming with an easy-to-learn operator interface. At more than 90 percent efficiency, the ProHeat 35 power source transfers more energy to the part, reducing operating costs over different heating methods. One ProHeat 35 power source can run a single or double rolling inductor setup. External cooler heat exchanger (300993) recommended when running a double rolling inductor setup.

Note: Primary input cable not included.

ProHeat Rolling Inductor (shown with mounting arm)

301117 30-foot power cable

301263 60-foot power cable

Liquid-cooled induction head for use with ProHeat 35, includes thermocouple extension cable and cable cover. The optional mounting arm allows the rolling inductor to ride on the top or side of the pipe.

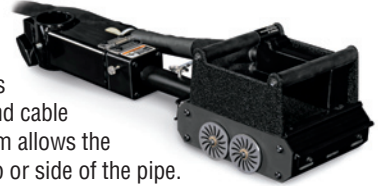

Running Gear 195436

The running gear adds to the portability of the system. The four 5-inch swivel casters with brakes mount to the bottom of the power source or cooler.

Infrared Sensor Connection Box 301182

Required for connecting the infrared temperature sensor to the ProHeat 35. The connection box allows for two infrared sensors to be connected to one ProHeat. Includes air regulator and filters.

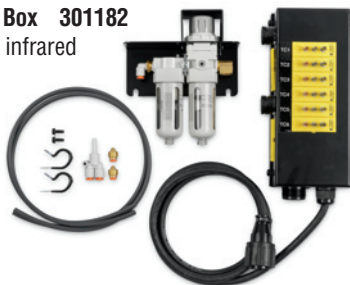

Heavy-Duty Induction Cooler

951686 Cooler with coolant (US and Canada only)

301298 Cooler only (not available in US and Canada)

The heavy-duty induction cooler is designed with an efficient fin-and-tube heat exchanger, 2.5-gallon rustproof polyethylene tank, high-pressure pump and blower to yield a high cooling capacity. When using two rolling inductors on one system it is recommended to add the external cooler heat exchanger, see Additional Accessories section.

ProHeat™ 35 Rolling Induction System (Continued)

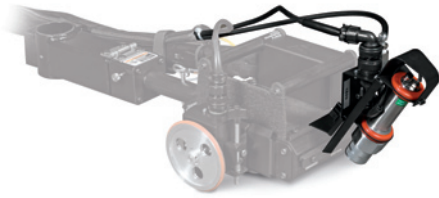

Infrared Temperature Sensor 301149
Eliminate the need for constant manual monitoring. The infrared temperature sensor can read the temperature of a moving part. Set the desired preheat temperature and the system will quickly heat to that temperature and hold it. The sensor can read from 122 to 752 degrees Fahrenheit (50–400°C). Requires infrared sensor connection box 301182.



Travel Detect System 301183
Avoid overheating — heating rates automatically adjust to varying travel speeds, and when no movement is detected the travel detect system turns off the output preventing damage to the workpiece and rolling inductor. The travel detect system can also be used for setting different heating rates based on workpiece speed of travel. Includes all cabling and mounting hardware.

Additional Accessories



External Cooler Heat Exchanger 300993
Increases the cooling capacity of the heavy-duty induction cooler. It is recommended when powering two rolling inductors on one ProHeat 35 power source.



Remote Contactor Control 043932
Remotely start and stop the heating process with this wired rocker switch remote. Includes a 25-foot (7.6 m) cable.



RHC-14 Remote Hand Control
242211020 20 ft. (6 m)
242211100 100 ft. (30.5 m)
Remotely adjust the heat output of the system in remote mode as well as start and stop the heating process.



RMS-14 Momentary Switch 187208
Momentary-contact switch for contactor control. Rubber-covered dome switch ideal for repetitive on-off applications. Includes a 26.5-foot (8 m) cable.

Specifications (Subject to change without notice.)

ProHeat 35 Power Source

| Input Power | Ambient Temperature Range | | Rated Output | Input Amperes at Rated Output | KVA/KW at Rated Output | Dimensions | Weight |
|--|-------------------------------|-----------------------------|-----------------------------|-------------------------------|------------------------|--|---|
| | Storage | Usage | | | | | |
| 460–575 V, 3-phase, 60 Hz  | -40 to 131°F (-40 to 55°C) | 4 to 131°F (-15 to 55°C) | 35 kW at 100% duty cycle | 50 A, 460 V 40 A, 575 V | 39/37 | H: 27.5 in. (699 mm) W: 21.75 in. (552 mm) D: 36.75 in. (933 mm) | Net: 227 lb. (103 kg) Ship: 265 lb. (120 kg) |
| 400–460 V, 3-phase, 50/60 Hz, CE | | | | 60 A, 400 V 50 A, 460 V | | | |

 Certified by Canadian Standards Association to both the Canadian and U.S. Standards.

 Manufactured and certified in accordance with IEC-60974-1, -10.

ProHeat Rolling Inductor

| Rated Output | Ambient Temperature Range | | Maximum Part Preheat Temperature | Required Cooler | Dimensions | Shipping Weight |
|--------------------------------|-------------------------------|----------------------------|----------------------------------|--------------------------------|--|------------------|
| | Storage | Usage | | | | |
| 300 amps at 100% duty cycle | -40 to 180°F (-40 to 82°C) | 32 to 140°F (0 to 60°C) | 600°F (315°C) | Heavy-duty induction cooler | H: 5.25 in. (133 mm) W: 6.6 in. (168 mm) D: 8 in. (203 mm) | 40 lb. (18.1 kg) |

Rolling Inductor Dimensions

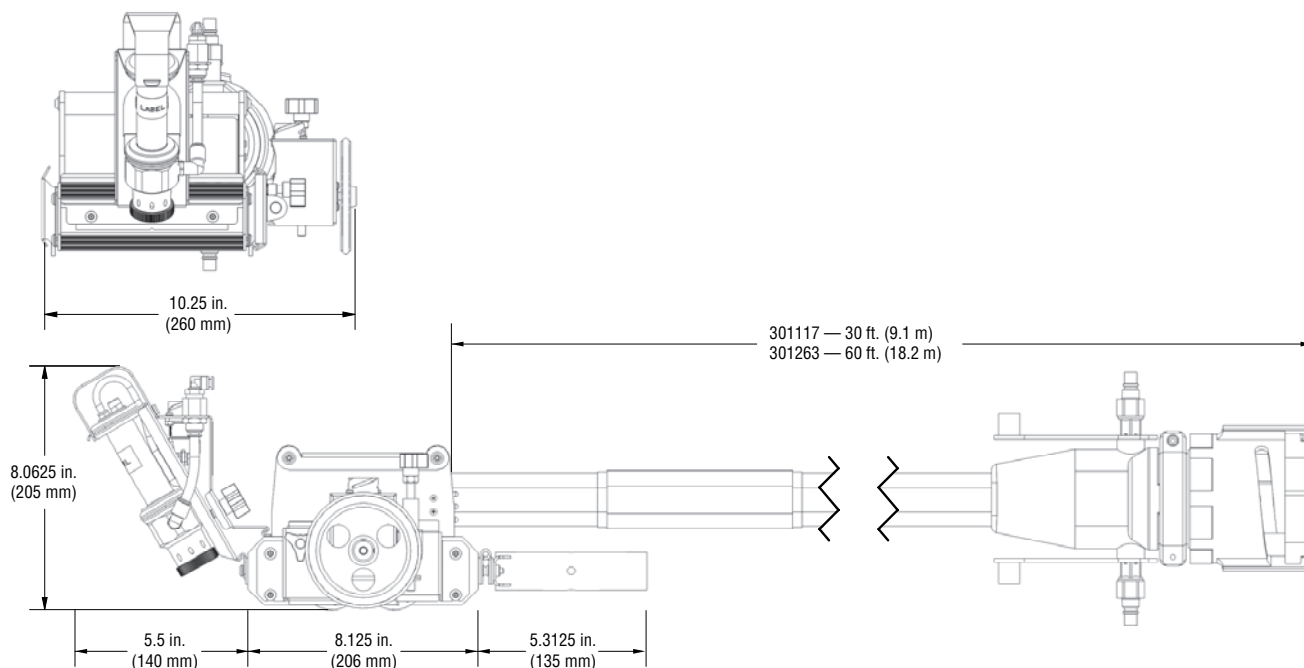

Ordering Information

| Equipment and Options | Stock No. | Description | Qty. | Price |
|--------------------------------|------------------|--|------|-------|
| ProHeat™ 35 | 907689 | 460–575 V, 3-phase, 60 Hz, 35 kW power source | | |
| | 907690 | 400–460 V, 3-phase, 50/60 Hz, 35 kW power source, CE | | |
| Heavy-Duty Induction Cooler | 951686 | Cooler with coolant (US and Canada only) | | |
| | 301298 | Cooler only (not available in US and Canada) | | |
| External Cooler Heat Exchanger | 300993 | Increases the cooling capacity of the cooler, recommended when running two rolling inductors on one power source | | |
| Coolant | 043810 | One gallon of low-conductivity coolant. Must be ordered in multiples of four (one case) | | |
| Running Gear | 195436 | Attaches to bottom of power source or cooler | | |
| Rolling Inductor | 301117 | 30 ft. (9.1 m) liquid-cooled induction head. Includes thermocouple extension cable and cable cover | | |
| | 301263 | 60 ft. (18.2 m) liquid-cooled induction head. Includes thermocouple extension cable and cable cover | | |
| Infrared Temperature Sensor | 301149 | Attaches to the rolling inductor. Measures the temperature of moving parts from 122–752°F (50–400°C). Requires infrared sensor connection box 301182 | | |
| Infrared Sensor Connection Box | 301182 | Attaches to the power source. Allows for the connection of two infrared temperature sensors | | |
| Travel Detect System | 301183 | Attaches to the rolling inductor. Comes with cabling and mounting hardware | | |
| Mounting Arm | 301119 | Attaches to the rolling inductor for mounting to pipe stand | | |
| Remote Contactor Control | 043932 | 25 ft. (7.6 m) wired remote on/off for power source | | |
| RHC-14 Remote Hand Control | 242211020 | 20 ft. (6 m) wired remote for heat and on/off for power source | | |
| | 242211100 | 100 ft. (30.5 m) wired remote for heat and on/off for power source | | |
| RMS-14 | 182208 | 26.5 ft. (8 m) momentary contactor switch for repetitive on-off applications | | |

Date:

Total Quoted Price:

Distributed by:

